



JANUARY 2021

M.K INFRASTRUCTURE (P) LTD.

OUR VISION, YOUR SAFETY

TABLE OF CONTENTS

| | |
|---|-----------|
| CORPORATE OVERVIEW | 3 |
| • About Us | 3 |
| • Brief History | 4 |
| • Why choose us? | 5 |
| • Our Approach | 5 |
| OUR PRODUCTS & SERVICES | 6 |
| • Rock fall protection system & slope stabilisation system & flexible Rock fall barrier | 6 |
| • Portable Toilets / Bio - Toilets & Bathing Cubicles | 8 |
| • Road Safety Furniture | 11 |
| • Metal Beam Crash Barrier | 29 |
| • Overhead Sign Boards/Gantry | 32 |
| • Retro Reflective Sheeting | 35 |
| • Prefabricated Shelter | 37 |
| • Building & Infrastructure works | 38 |
| CONTACT US | 39 |

Corporate overview

ABOUT US

MK Infrastructure (P) Ltd has been leading the industry in fabrication, supply of road safety furniture, construction of road infrastructure and building and construction works. With its successful partnerships on several high-risk projects with the Central and State government, The Indian Army and private companies, the company, over the past 30 years brings along great experience in serving with the same commitment it has for the past three decades.

Working towards fulfilling the nation's infrastructure goal, we at M.K Infrastructure have been committed to realizing these objectives.

30+

Years into the
business

40+

Clients
served

60+

Projects
completed

5000+

Products
delivered

Our mission

M.K Infrastructure (P) Ltd has been committed to providing valued quality products at competitive prices with the highest standards of after service for over thirty years. We use the most advance and innovative technology to deliver quality solutions to our clients without limiting ourselves to any regional limits or boundaries.

Our vision

Our company aims to emerge as an industry benchmark across each of its verticals through a combination of ethical standard, operating efficiency, product quality and superior service. We are committed to be a preferred partner for all our stakeholders through a consistent ability to enhance their respective value.

BRIEF HISTORY

Our parent company O.P. Kandoi & Co. came into being in 1972 and soon rose to become Class 1 contractor with Central Public Work Department (CPWD). Keeping with the times and growing expectations from our company we decided to expand and diversify our activities. This is how M.K. Infrastructure (P) Ltd. was born in the year 2003 with its registered office in Siliguri, West Bengal. Our main focus is on providing and maintaining road safety systems of international standard.

Till this time the modern road safety system existed mostly in metropolitan cities of our country and it was a new concept, especially in the North Eastern States, Sikkim and neighbouring countries such as Bhutan and Nepal.

With growing demands, the company expanded its operations to different states and union territories - Assam, Arunachal Pradesh, Meghalaya, Sikkim, New Delhi and Port Blair. Eventually, we also expanded our operations internationally with projects in Bhutan and Nepal.

Our present range of business includes:

- Designing, execution and construction of Buildings, State & National Highways and Bridges etc.
- Full range of latest Road Safety Systems which include Reflective Signage & Sheeting, Road Marking with Hot Thermoplastic Paint, Metal Crash Barriers/Guard Rails, Reflective Pavement Marker, Delineators, Acrylic Reflectors, LDS, Photo-Luminescent Signs, Modular Speed Breakers/Rumbler, Median Marker and Solar Powered Road Safety Equipment etc.
- Construction & supply of toilet blocks and bathing cubicles, etc.
- We undertake 'turn-key' projects also
- Subsequently, keeping in view diversification of activities, M K Infrastructure (P) Ltd entered into a contract with the Ministry of Defence During the year 2007 for providing and erecting Prefabricated shelters for troops in forward areas of Sikkim where sub-zero condition prevails throughout the year
- We also deal in execution and supply of rockfall protection system, flexible slope stabilisation system & flexible rockfall barrier that helps in preventing landslides, rockfalls, debris flow and avalanches

With the growing needs of a sustainable and a self-reliant future, the Indian government has taken up new initiatives and have developed several infrastructure policies. This has led our company to come up with innovative & sustainable solutions in the field of hybrid solar power, flexible rockfall barrier & slope stabilisation systems and light weight toilet/bio-toilets & bathing cubicles.

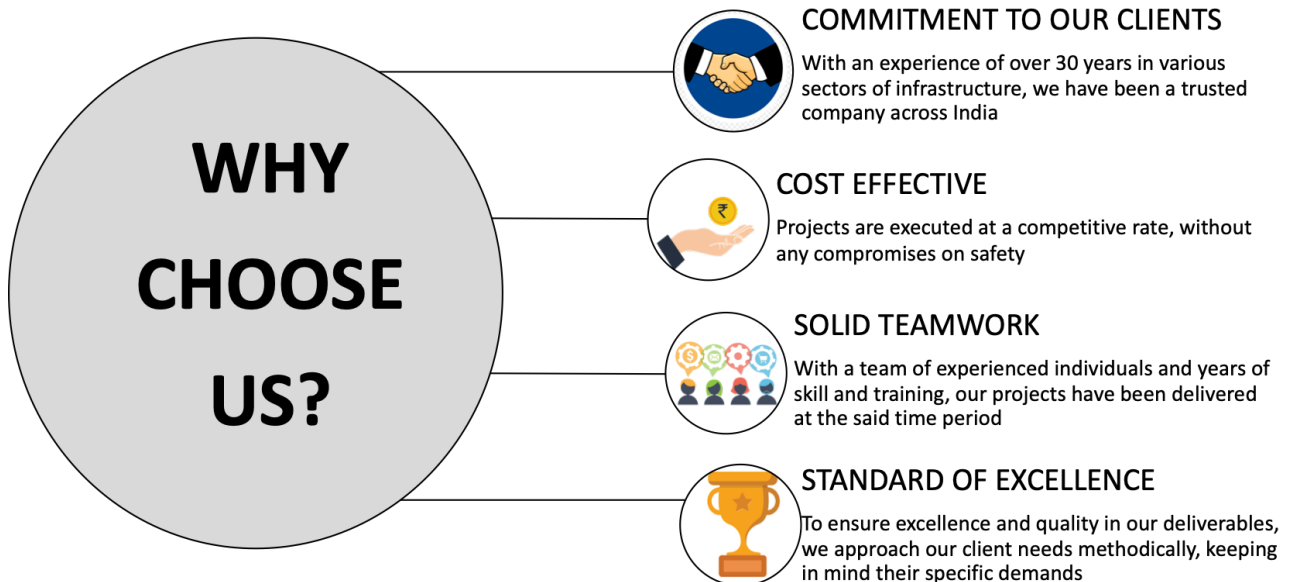

OUR APPROACH

1 **Understanding client's need**
 Inception of any work demands knowing the needs of the client in order to develop a strategy.

2 **Surveying the location**
 After having understood the needs, surveying through the site is the next call for action

3 **Designing the framework**
 After a thorough investigation of the site, a road map is drawn for the execution of the project

4 **Supply and Execution**
 Based on the blueprint, the project is executed and the materials are supplied within the time period

Our Products

ROCKFALL PROTECTION SYSTEM & SLOPE STABILISATION SYSTEM & FLEXIBLE ROCKFALL BARRIER

Rapid infrastructure growth and demand of smooth connectivity in the mountainous region is leading to non-scientific cutting off slopes which is resulting in continuous landslides, rockfalls, debris flow and avalanches.

With the increase in infrastructure development in these areas, we entered into a joint venture with P & G Geohazard Solutions (P) Ltd. to provide cutting edge protection solutions against natural hazards for highways, tunnels, defence establishments, hydro power plants etc. P & G Geohazard Solutions (P) Ltd. more than ten years of experience in the field of natural hazard mitigation and it has the ability to offer the most appropriate solutions without product constraints.



Flexible Slope stabilisation system

With its vast experience in disaster mitigation solutions and Lidar Survey below are some of the landmark projects in disaster mitigations executed:

1. Design, supply & execution of Slope stabilization system for approach road to North portal of Nashri - Chenani Tunnel, J&K.

2. Protection of track road to Shri Mata Vaishno Devi Shrine at Katra, J&K.
3. Design & supply of rockfall protection & slope stabilization system for western & ventilation portal at Z- Morh Tunnel, J&K.
4. Design, supply & execution of rockfall protection & slope stabilization system for Kiratpur - NerChwok Expressway, Himachal Pradesh
5. Design, supply & execution of rockfall protection system for Khed - Sinnar Expressway, Maharashtra

Rockfall protection systems are primarily categorised into two types: Active and Passive systems. Rockfall barriers, debris flow barriers, shallow landslide barriers, drapery systems are considered as passive protection systems whereas slope stabilization systems using hard or flexible fascia are considered as active protection system.

Active mitigation is necessary when there is a real danger of falling rocks. The installed rockfall protection systems must be able to absorb the impact of falling rock. Passive mitigation is necessary when the scenarios is intended as a preventive way of controlling rockfalls.

We offer solutions from project planning to execution and acceptance. We have an experience of executing more than 20 flexible rockfall barriers and more than 1,00,000 sqm of flexible slope stabilization system/rockfall protection systems in India.



Rockfall protection system

PORTABLE TOILETS / BIO - TOILETS & BATHING CUBICLES

Over the years, the toilets/bio-toilets manufactured and supplied have definitely fulfilled its basic objective but with the growing developmental needs and infrastructure in high terrains, the toilets and shelters supplied have not been at par with the newer requirements. Our toilets/bio-toilets & bathing cubicle is constructed in order to fulfil these newer needs and keep pace with the changes introduced.



Portable toilets with fire extinguisher installed



Portable toilets with fitted wash basin

With our primary focus on sustainable and light weight toilets/bio-toilets, we propose in using a portable bio-toilet which can withstand high and low temperatures up to - 20 C. With a rock solid built, these toilets can last up to 10 years or more. These bio-toilets are flame retardant and the material is made with RDSO, SPECS and the same is supplied to the Indian railways. These bio-toilets being light weight can be easily transported and used in different rough terrains. Our company, M.K Infrastructure (P) Ltd. in partnership with Milton Industries Limited is an authorised Original Equipment Manufacturer (OEM) for these toilets/bio-toilets.

Some of the notable features of the portable toilets is mentioned below:



The Whole Unit is thermally insulated and can maintain the temperature, and is temperature resistant which can withstand temperature up to -20 degree centigrade



Material used in construction is electrically insulated and eliminates risk and threat of electrical shocks



Material of Construction: FRP sandwich with PU foam for Wall, Roof and Floor. This allows for weather and thermal insulation



Dimensions of the Product: 4'x4'x8'. It can be customised as per need. Moreover, we can also customise the interior as per need of the final customer. However, a minimum quantity would apply in that case.



Weight of the Product: Approximately 180 kgs (including all necessary fittings)



Thickness: Wall (16mm), Roof (4mm), Floor (31mm)



Flame retardant: These bio-toilets are flame retardant and the material used in making conforms to the Research Design & Standards Organisation (RDSO) specifications and UIC 564-2 standard

These toilets are easier to move / relocate, easy and quick to install (just connect with electrical, water input and draining output), no need to assemble, takes very little space, clean to use, design can be customised as per usage. The floor is FRP with chequered design which would be anti-slip. All electrical fittings will be provided and it can also be customised. These products can be fitted with an Indian or W/C as per requirement. Each unit is a standalone unit and hence completely modular and detachable. No need of exterior or interior paint as the surface finish and texture will remain for about 10 years or more. Electric geyser along with solar power panels can also be added



Anti-slip flooring



Fitted with electrical supplies



Fitted with basin & dustbin



Installed with jaguar fittings

ROAD SAFETY FURNITURE

Working in this field for over 30 years, our company has dedicated itself to making the Indian roads safer. We have partnered with many government organisations to install quality road safety furniture at a competitive rate without compromising on the safety, efficiency, and durability of the products.



Mentioned below are the different categories of road safety furniture available with us:

1. ROAD STUDS: Road Studs or road reflectors are devices made to provide visibility at night or in adverse weather conditions. They are available in plastic/abs, aluminum and solar

A. ABS Road Stud

| | |
|---|---|
|  | <p>Dimension: 100x100x20 mm</p> <p>Direction: Two-way acrylic prismatic reflector</p> <p>Colour: Yellow, White, Red</p> |
|  | <p>Dimension: 100x90x18 mm</p> <p>Direction: Two-way acrylic prismatic reflector.</p> <p>Colour: Yellow, White, Red</p> |
|  | <p>Dimension: - 100(L)x90 mm(W)x 18(H)mm</p> <p>Compressive Strength (Breaking Load): 38,878 Kg</p> <p>Flexural Strength: 1983 Kg Lens Impact</p> |

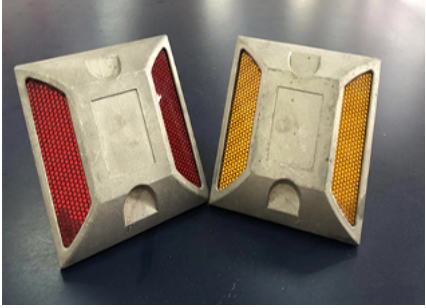
B. Aluminum Road Stud

| | |
|---|---|
|  | <p>Dimension: 100x100x20mm</p> <p>Direction: Two way reflective</p> <p>Reflector: Prismatic lense reflector</p> <p>Colour: Yellow, White, Red</p> <p>Available: With Inbuilt Shank</p> |
|  | <p>Dimension: 100x100x20mm</p> <p>Direction: Two way Reflective</p> <p>Reflector: 21 Glass Beads Each Side Length Anchoring</p> <p>Shank: 50mm</p> <p>Material: Aluminium Alloy Body</p> <p>Colour: Yellow, White, Red</p> <p>Available: With Nail or Shank</p> |
|  | <p>Dimension: 100x100x20mm</p> <p>Direction: Two way Reflective</p> <p>Reflector: 43 Glass Beads Each Side.</p> <p>Colour: Yellow, White, Red</p> <p>Available: With Nail or Shank</p> |

C. Solar Road Stud

| | |
|---|--|
|  | <p>Dimension: 110x110x72mm with shank</p> <p>Direction: Two way Reflective</p> <p>LED: 3 on each side</p> <p>Colour: Amber and Red</p> |
|  | <p>Dimension: 132x122x72mm with shank</p> <p>Direction: Two way Reflective</p> <p>LED: 3 on each side</p> <p>Colour: Amber and Red</p> |
|  | <p>Dimension: 132x122x72mm with shank</p> <p>Direction: Two way Reflective</p> <p>LED: 3 on each side</p> <p>Colour: Amber and Red</p> |

2. **DELINEATORS:** Delineators are ideally suitable for dangerous central verges, islands, sharp curves etc. High quality reflectors fixed on both sides make it highly visible in poor light conditions. They can be installed horizontally and vertically. Due to specially designed body and reflectors fixation method, their reflectivity remains for a longer shelf life.

A. Rigid Reflector

| | |
|---|--|
|  | <p>Height: 1200 mm</p> <p>Width: 110mm x 34 mm</p> <p>Reflective area: 300 Sq. Cms</p> |
|---|--|

B. Metal Delineator

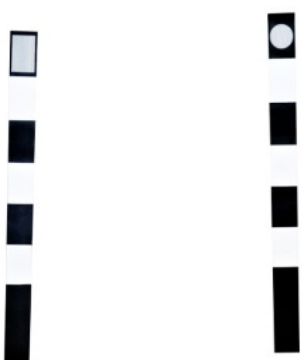
| | |
|--|---|
|  | <p>Dimension: 100x 25x 1200 mm</p> <p>Reflective Tape: HIP Grade- 80x120 mm or 80 Circle, Both Side</p> <p>Width: 150mmx 100 mm x 3 nos Both Side</p> <p>Colour: Black Powder Coating</p> |
|--|---|

C. Guide Post

| | |
|---|---|
|  | <p>Direction: Two way reflector Metal Body</p> <p>Colour: Orange and White Combination</p> <p>Height: 750mm, 1000mm, 1200mm</p> |
|---|---|

D. Solar Delineator

| | |
|---|--|
|  | <p>Light Dimension: 70x70x100mm</p> <p>Pipe Dimension : 48x1000mm</p> <p>Direction: 360</p> <p>Degrees Round</p> <p>Light: Protection with Top MS Mesh fitted</p> <p>Viewing Distance: 500 meters</p> <p>Warranty: 2 years</p> |
|---|--|

E. Spring Post: Flexible Posts are used to guide traffic or to provide warning of approaching hazards. You can use the Flexible Post in any situation where you must separate traffic simply and safely. It can be bolted to the floor using the base. It will allow emergency services to travel over them when needs be which makes it the most suitable option of separating traffic on busy public roads.

| | |
|---|--|
|  | <p>Height: 750mm</p> <p>Upper Diameter: 80mm</p> <p>Body Materials: Strong Flexible UV Protected PU & PVC</p> <p>Reflective Band: High Intensity Reflective Light Material Crystal Lattice Weathering</p> <p>Resistance: 3 years</p> |
|---|--|

| | |
|---|---|
|  | <p>Dimension: Length 750mm x Width 250mm</p> <p>Weight: 2.25 kgs</p> <p>Body Materials: Moulded in ABS- PC Alloy, UV Stabilized</p> <p>Colour: Yellow and Black</p> |
|---|---|

3. **TRAFFIC CONE:** Traffic cones are extremely durable, portable and brightly coloured. These can be a perfect partner in boosting safety measures to a higher level. We can see these in high danger zones like construction sites, crowded streets, corridors and hallways. These safety cones are very helpful in keeping work hazards away.

| | |
|---|--|
|  | <p>Height: 750 MM</p> <p>Weight: 3.5 Kgs</p> <p>Base: 400 x 400 mm</p> <p>Material : HDPE Reflective Tape</p> <p>Size: 150mm</p> |
|---|--|

| | |
|--|--|
|  | <p>Height: 750mm</p> <p>Weight: 1.2 Kgs</p> <p>Base: 385 x 385mm</p> <p>Material: LDPE Reflective Tape</p> <p>Size: 100mm</p> |
|  | <p>Height: 1000mm</p> <p>Weight: 4.5 Kgs</p> <p>Base: 500 x 500mm</p> <p>Material: HDPE Reflective Tape</p> <p>Size: 150mm</p> |

4. SPEED BREAKER / PORTABLE SPEED BREAKER: Speed bumps are designed to get the drivers to reduce their speed at critical junctions. This could mean pedestrian areas crosswalks, toll collection booths, security gates etc. Our Polymer base Speed bump with Hexacore design has become the go-to standard for malls, institutions and toll booths.

A. Plastic

| | |
|---|---|
|  | <p>Body material: Thermoplastic Engineering Alloy</p> <p>Dimension: 250mm (L) x 350mm (W) x 50mm(H)</p> |
|---|---|

| | |
|--|---|
|  | <p>Body material: Thermoplastic Engineering Alloy</p> <p>Dimension: 500mm (L) x 380mm (W) x 75mm(H)</p> |
|  | <p>Body material: Thermoplastic Engineering Alloy</p> <p>Dimension: 250mm (L) x 750mm (W) x 75mm(H)</p> |
|  | <p>Body material: Thermoplastic Engineering Alloy</p> <p>Dimension: 500mm (L) x 380mm (W) x 50mm(H)</p> |

B. Rubber: Long lasting and cost-effective rubber product maximum visibility, even at night, thanks to its flexible rubber material resistant to extreme temperature variations, UV light, oil and moisture, easy maintenance.

| | |
|---|---|
|  | <p>Body material: Thermoplastic Engineering Alloy</p> <p>Dimension: 500mm (L) x 130mm (W) x 25mm(H)</p> |
|---|---|

| | |
|---|---|
|  | <p>Body Material: EPMD Rubber</p> <p>Colour: Yellow and Black</p> <p>Dimension: 500mm (L)x 350mm (W) x 50mm (H)</p> |
|---|---|

5. **MEDIAN MARKER:** The product is made of tough, impact-resistant thermoplastic body, reflectorized on either side using fluorescent yellow prismatic sheeting. It is designed to take rigors of natural weathering, making the product extremely durable.

| | |
|---|------------------------------------|
|  | <p>Size: 105mm x 105mm x 150mm</p> |
|  | <p>Size: 105mm x 105mm x 150mm</p> |
|  | <p>Size: 100mm X 100mm X 100mm</p> |

- A. Flexible: This product ensures high visibility of medians/pavements in the night or rainy conditions.

| | |
|---|--|
|  | <p>Height - 185 mm</p> <p>Width – 125 mm</p> |
|---|--|

6. SOLAR ROAD PRODUCTS: Solar Road Products offered by us consist heavy duty panels, Technical Circuit, Operating systems and Battery for storage of Solar Energy in device.

- A. Solar Warning Light: The Solar Powered Warning Lights incorporate the latest photovoltaic technology into a compact efficiently designed solar powered barrier warning light package. The battery has rechargeable capabilities that replace a conventional system. By employing renewable energy, which is free, constant and non-polluting, the SOLAR Lights eliminate maintenance and disposal costs.

| | |
|---|---|
|  | <p>Height: 15.5 cm</p> <p>Diameter: 9 cm</p> <p>Function: Flash Close ABS base</p> <p>LED: 4 Pcs Led Fitted</p> <p>Battery: Inbuilt</p> |
|  | <p>Diameter: 9 cm</p> <p>Function: Flash Close ABS Base</p> <p>Led: 4 Pcs Led Fitted</p> <p>Battery: Inbuilt</p> |

- B. Solar Flasher: The Solar Barricade Light provides unsurpassed performance by utilizing the power of the sun at your road side project.

| | |
|---|---|
|  | <p>Height: 22cm</p> <p>Diameter: 18cm</p> <p>Function: Flash Close ABS base</p> <p>LED: 6 Bright LED fitted</p> <p>Battery: Inbuilt</p> |
|---|---|

- C. Solar Blinker Traffic Light: Manufactured using a superior quality raw material, these Traffic blinker signals are known for their uninterrupted operations and self-generated power. Owing to their microcontroller-based charge regulator and solar panel assembly, these Blinker Lights are widely demanded by the clients.



| | |
|---|---|
|  | <p>Size: 200 mm</p> <p>Body Material: Polycarbonate Body</p> <p>Solar Panel: 20 W with micro controlled solar charger</p> <p>LED: 22 Bright LED Encapsulated in Convex Lense</p> <p>Battery: 4.5 AH</p> <p>Warranty: 1 year</p> |
|---|---|

| | |
|---|---|
|  | <p>Size: 300 mm</p> <p>Body Material: Polycarbonate Body</p> <p>Solar Panel: 20 W with micro controlled solar charger</p> <p>LED: 172 Bright LED</p> <p>Battery: 7 AH</p> <p>Warranty: 1 year</p> <p>Also, available in Metal Body and 400 mm Diameter.</p> |
|---|---|

D. Solar Mobile Traffic Light: Solar mobile traffic lights are built around the idea that if an actual installed system is failed, the mobile system can be towed to the troubled site and placed in a matter of few minutes. It works practically like an actual Intersection Light for 3 working days even if the power supply is disconnected. It is also useful at accident site.

| | |
|---|---|
|  | <p>Size: 300mm (Powder Coated)</p> <p>Body Material: CRC Sheet of 1mm Metal Platform</p> <p>Light Material: Polycarbonate</p> <p>Led: 61 Bright Led Encapsulated In convex lens</p> <p>Battery: 12 Volts 65 AH.</p> |
|---|---|

E. Solar Sign Board

| | |
|---|--|
|  | <p>Dimension: 450x600x52mm</p> <p>Direction: Moving and Blinking</p> <p>Solar Panel: 5 Watts Panel with Micro Controlled Solar Charger</p> <p>LED: 35 Bright LED Encapsulated in Convex Lens</p> <p>Battery: Lion 6, 4.5 Ah Battery</p> |
|  | <p>Dimension: 600mm Circular</p> <p>Direction: Moving and Blinking</p> <p>Solar Panel: 5 Watts Panel with Micro Controlled Solar Charger</p> <p>LED: 130 Bright LED Encapsulated in Convex Lens</p> <p>Battery: Lion 6, 4.5 Ah Battery</p> |
|  | <p>Dimension: 900mm Triangle</p> <p>Direction: Moving and Blinking</p> <p>Solar Panel: 5 Watts Panel with Micro Controlled Solar Charger</p> <p>LED: 130 Bright LED Encapsulated in Convex Lens</p> <p>Battery: Lion 6, 4.5 Ah Battery</p> |

7. RUBBER PARKING SAFETY PRODUCTS: These products are ideally suited for use in areas like car parks, warehouses and other applications. Some of its features include safeguarding vehicles from possibility of dents and scraping.

A. Corner Guard (L shape and Round Shape)

| | |
|---|---|
|  | <p><u>Dimension: 800, 900, 1000 and 1200 mm</u></p> <p><u>Body Material: Rubber</u></p> <p><u>Reflectors: High Quality Retro Reflective</u></p> |
|---|---|

B. Wheel Stopper

| | |
|--|---|
|  | <p>Dimension: 500x160x152mm 600x120x100mm</p> <p>Body material: Rubber</p> <p>Reflectors: High Quality Retro Reflective</p> |
|--|---|

C. Dock Bumper

| | |
|---|---|
|  | <p>Dimension: 450x240x100mm</p> <p>Body material: Rubber</p> <p>Reflectors: High Quality Retro Reflective</p> |
|---|---|

D. Wheel Clock

| | |
|---|---|
|  | <p>Dimension: 275x225x250 mm 375x200x225 mm</p> <p>Body Material: Rubber</p> <p>Reflectors: High Quality Retro Reflective</p> |
|---|---|

8. CONVEX MIRROR: Convex Mirror is ideal for any area where an unobstructed view is required. The mirror faces are manufactured from shatterproof acrylic and come with heavy duty fittings and will provide years of maintenance free service.

|  | <table border="1"> <thead> <tr> <th>Diameter</th> <th>Body Material</th> <th>Weight</th> <th>Packing Size</th> <th>Fixing Measure</th> </tr> </thead> <tbody> <tr> <td>450 mm /18 inch</td> <td>Polycarbonate</td> <td>2160 gms</td> <td>18x20 inch</td> <td>Camps and Bolts</td> </tr> <tr> <td>600 mm /24 inch</td> <td>Polycarbonate</td> <td>2600 gms</td> <td>24x24 inch</td> <td>Camps and Bolts</td> </tr> <tr> <td>800mm /32 inch</td> <td>Polycarbonate</td> <td>5080 gms</td> <td>33x33 inch</td> <td>Camps and Bolts</td> </tr> <tr> <td>1000mm/ 39 inch</td> <td>Polycarbonate</td> <td>6920 gms</td> <td>39x39 inch</td> <td>Camps and Bolts</td> </tr> </tbody> </table> | Diameter | Body Material | Weight | Packing Size | Fixing Measure | 450 mm /18 inch | Polycarbonate | 2160 gms | 18x20 inch | Camps and Bolts | 600 mm /24 inch | Polycarbonate | 2600 gms | 24x24 inch | Camps and Bolts | 800mm /32 inch | Polycarbonate | 5080 gms | 33x33 inch | Camps and Bolts | 1000mm/ 39 inch | Polycarbonate | 6920 gms | 39x39 inch | Camps and Bolts |
|--|--|----------|---------------|-----------------|--------------|----------------|-----------------|---------------|----------|------------|-----------------|-----------------|---------------|----------|------------|-----------------|----------------|---------------|----------|------------|-----------------|-----------------|---------------|----------|------------|-----------------|
| Diameter | Body Material | Weight | Packing Size | Fixing Measure | | | | | | | | | | | | | | | | | | | | | | |
| 450 mm /18 inch | Polycarbonate | 2160 gms | 18x20 inch | Camps and Bolts | | | | | | | | | | | | | | | | | | | | | | |
| 600 mm /24 inch | Polycarbonate | 2600 gms | 24x24 inch | Camps and Bolts | | | | | | | | | | | | | | | | | | | | | | |
| 800mm /32 inch | Polycarbonate | 5080 gms | 33x33 inch | Camps and Bolts | | | | | | | | | | | | | | | | | | | | | | |
| 1000mm/ 39 inch | Polycarbonate | 6920 gms | 39x39 inch | Camps and Bolts | | | | | | | | | | | | | | | | | | | | | | |

9. SAFETY BARRICADES: Road barrier is a good alternative and has stood the test of time stackable FRB-1 ST are perfectly ideal for use as Road Barriers, Parking & Security Barriers, Toll Plaza Barriers and Highway Barriers.

Strong construction prevents damage due to vehicular impact; these barriers can also be filled with up to 50 Ltrs water for added stability. Designed with the purpose of channelling pedestrians and vehicles in construction zones, these lightweight barriers can be easily removed and set up in very little time.

| | |
|---|--|
|  | <p>Dimension: 1000(L)x500(W)x800(H)mm</p> <p>Water Filling Capacity: 15 Litre</p> <p>Colours: Red and White</p> |
|  | <p>Dimension: 2100(L)x600(W)x840(H)mm</p> <p>Effective Length: 2000mm (2 meter barricade)</p> <p>Water Filling Capacity: 80 Litre</p> <p>Colours: Red and Yellow</p> |
|  | <p>Dimension: 2020(L)x400(W)x1265(H)mm</p> <p>Effective Length : 2000mm(2 meter barricade)</p> <p>Colours: Red and Yellow</p> |
|  | <p>Dimension: 1640 (L)X400(W)X1000(H)mm</p> <p>Effective Length: 1500mm (1.5 meter barricade)</p> <p>Water filling capacity: 50 Ltr</p> <p>Colours: Red and Yellow</p> |

A. Que-Manager: This product is widely used to manage crowd or queues in an organized manner. Our range is made available to the clients in varied specifications to meet the exact requirements of the clients.

| | |
|---|--|
|  | <p>Base: 320mm</p> <p>Height: 910mm</p> <p>Weight: 7/10 kg</p> <p>Feature: Easy to install, Durable standards, Perfect Design.</p> |
|---|--|

B. Wheel Clamp Lock: This product is used for anti-theft of vehicles. It can be used to lock the vehicles in parking, traffic violation, parking violation.

| | |
|--|---|
|  | <p>Material: Made from heavy gauge hardness steel with locking system.</p> <p>Size: 490mm x 240mm x 70mm</p> <p>Features: It can be adjusted to fit 7 to 11 inches width tire. It is difficult to open without special tools.</p> |
|--|---|

C. Reflective Safety Jacket: These jackets have great reflectivity and make an individual visible at night or day.

| | |
|---|--|
|  | <p>These jackets are fabricated using advanced scientific and technical fabric and film tapes which enhances person's visibility from maximum and longest distances. They are fluorescent in colour and are UV stabilised.</p> |
|---|--|

10. Other Accessories for Road Safety

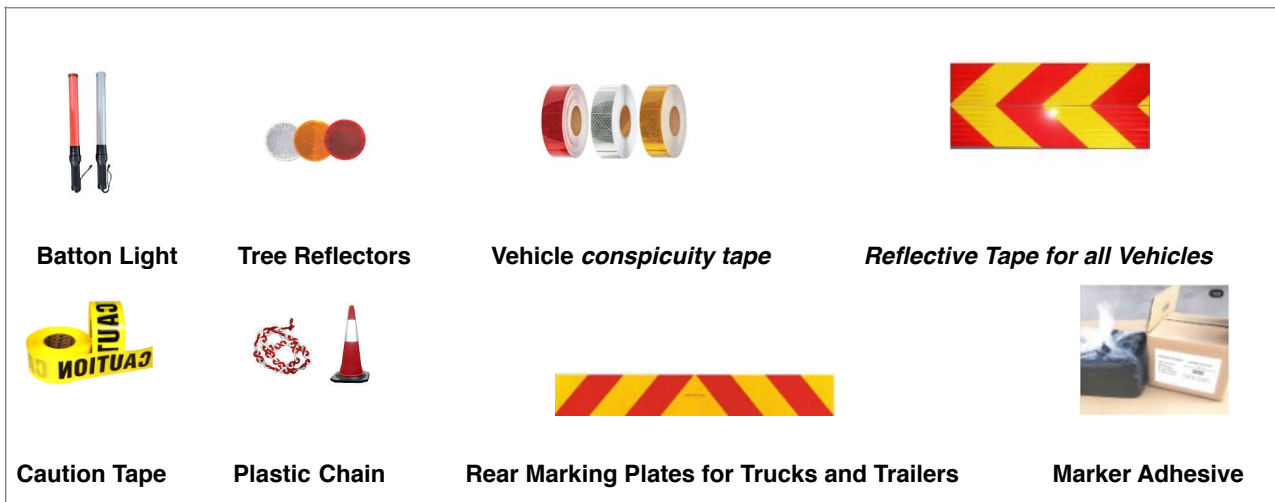

11. EPOXY ADHESIVE: These are used for road studs, median marker, speed breaker, delineator, spring post and other road furniture. The adhesive is based on specialize epoxy system (Resin and hardener and sand) to provide excellent adhesion of cat eye, speed breaker and other road furniture to the base of the road surface concrete.



12. THERMOPLASTIC ROAD MARKING PAINT: This road marking material is a synthetic resin-based thermosetting material which contains 100% thermoplastic solids and is both environment-friendly and solvent-free. It is also cost friendly, durable, reflective and highly visible.

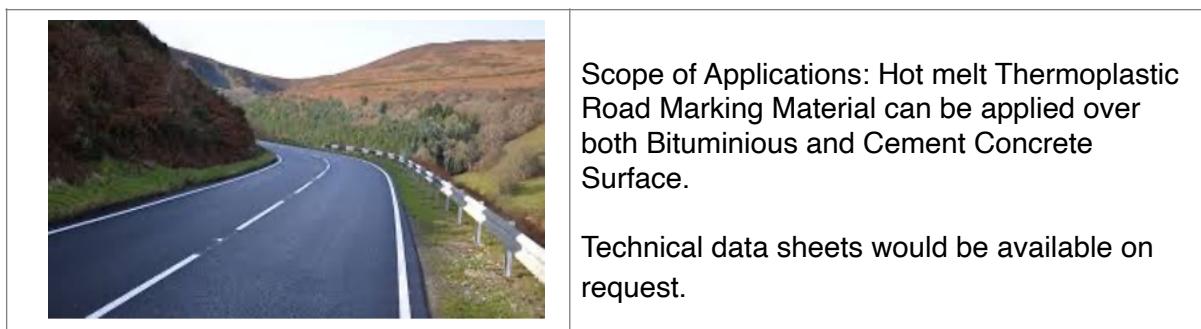

METAL BEAM CRASH BARRIER

Guardrail Barrier are used in highway and fixed on the side of the roads especially on curves and slopes for preventing vehicles from riding out from roads.

It can provide railing protection to motor vehicles at dangerous road areas such as steep slope, high embankments, obscure curves, sharp corners to absorb sudden impact during collision, thus minimizing injury to vehicle and passenger. The barrier also acts as a protector for pedestrians along the highway.



- A. W Beam Crash Barrier: A typical guardrail system consists of a steel W-Beam rail on steel posts with various designs of end treatments and transitions made from the same material.

Technical Specification (Customised as per Requirement)

- Cold roll formed in thickness 3.0 mm / 2.8mm / 2.67mm
- Hot-dip Galvanized to 550g /sqm
- W Beam Width 310mm
- Standard Galvanised finishing



B. Thrie Beam Crash Barrier: The Thrie Beam Guardrail features a triple wave shape, which has an added corrugation compared to the traditional W-beam. Compared to two-wave shape product, this design has a stronger construction and higher impact endurance. As such, it is useful in high volume traffic areas and high-speed roads and also in regions with hilly terrain.



Technical Specification (Customized as per Requirement)

- Cold roll formed in thickness 3.0 mm / 2.8mm / 2.67mm
- Hot-dip Galvanized to 550g /sqm
- Thrie Beam Width 510mm
- Standard Galvanised finishing



- a. Guard Rail Reflector (Light and Heavy): Guard Rail Reflectors with metal base is used on the side of metal crash barriers (W-type) along the highway. It perfectly delineates the road direction and helps the driver in night viewing.



- b. Glare Barricades: Anti-glare Screens or Anti dazzle boards have same functions, that is, to protect the traffic from headlights of oncoming traffic. It is usually used in combination with the central guardrail, central barrier (cement barrier and steel guardrail). It is designed to solve the glare of the headlights which can be a huge factor in blinding the drivers and cause accidents.



OVERHEAD SIGN BOARDS / GANTRY

- A. Mandatory/Regulatory Signs: These signs are mandatory on roads for it makes driving safer. They have generally black legend on a white background. They are circular in shape with red borders.



- B. Caution/Warning Signs



C. Informatory/Guide Signs: These signs provide information to the driver about the facilities available ahead, the route and distance to reach the specific destinations.

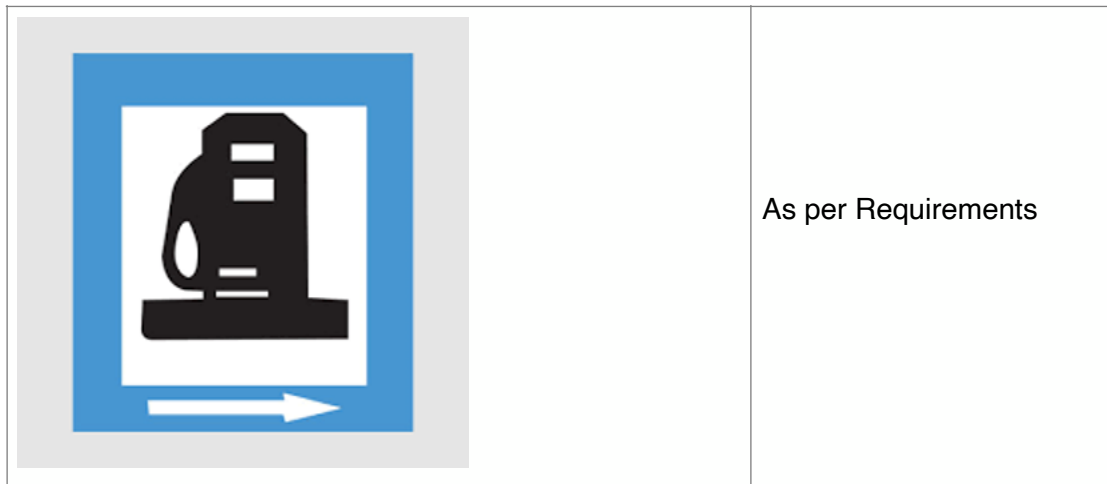

D. Overhead Gantry Board / Cantilever

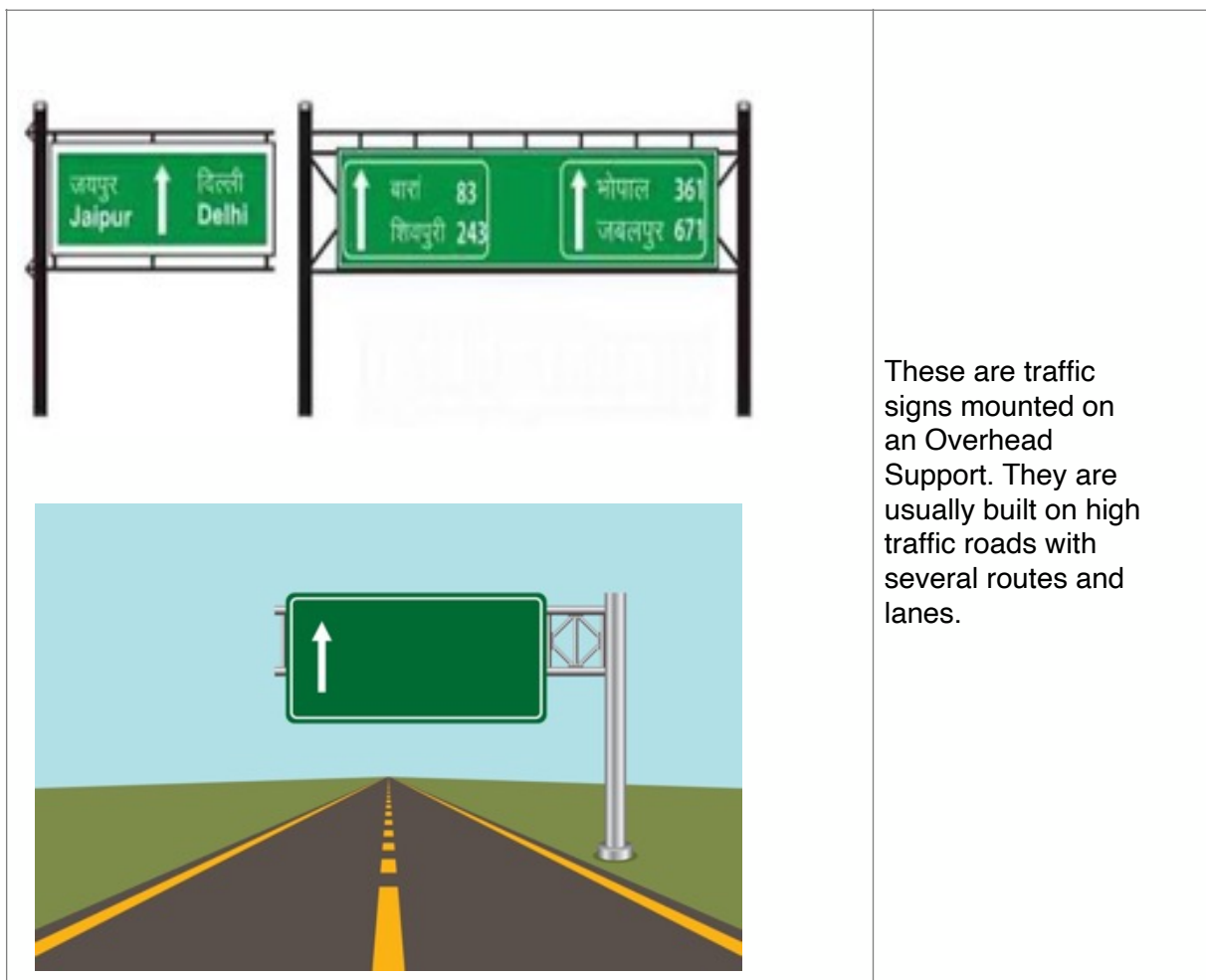

- E. Project Sign Boards: These boards are installed to any Road Project on behalf of the contractor on sites. The main intent of these boards is to ensure that consistent information is being communicated and it also provides visual consistency.

| | |
|---|----------------------------|
|  | <p>As per Requirements</p> |
|---|----------------------------|

- F. Hazard Marker and Chevron Sign Board: These boards are designed in compliance with IRC -67-2001 and MORTH specification. These are designed with a durable finish. Made of Retro Reflective sheeting and ACP base, these are long lasting in nature and not affected by adverse climatic condition.

| | |
|---|---------------------------|
|  | <p>As per Requirement</p> |
|---|---------------------------|

RETRO-REFLECTIVE SHEETING

- A. Commercial Grade Reflective Sheeting: Retro-Reflective Sheeting is fabricated using synthetic resin that sturdily resists the damaging effect of changing weather and even impacts high reflectivity, particularly at night. The sheets have mainly been designed for using on vehicle license plates and traffic signs contributing greatly to public safety.

| | |
|---|--|
|  | <p>Enclosed lens reflective sheeting</p> <p>Reflectivity: Exceeds specification ASTM D 4956-04 Type 1.</p> <p>Best For: Such materials are utilized for short time advertisements/signs, sticker, number plates within areas having low volume, little competing surrounding lights and lower speed traffic.</p> |
|---|--|

- B. High Intensity Prismatic Grade Reflective Sheeting (HIP)

| | |
|---|---|
|  | <p>Exclusive prismatic construction sheeting, backed by reliability.</p> <p>Reflectivity: Exceeds specification ASTM D 4956-04 Type 4.</p> <p>Best for: Permanent and temporary signages, high quality durability, micro prismatic material with pressure sensitive adhesive.</p> |
|---|---|

- C. Prismatic Engineering Grade Reflective Sheeting (PEG)

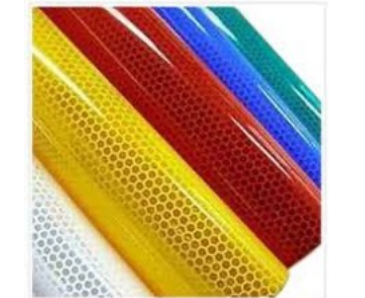
| | |
|---|---|
|  | <p>Exclusive prismatic sheeting, backed by reliability</p> <p>Reflectivity: Exceeds specification ASTM D 4956-04 Type 4</p> <p>Best for: All traffic situations. Prismatic Engineering Grade is extremely reflective at large angles for the approaching traffic.</p> |
|---|---|

D. Premium Prismatic Grade Reflective Sheeting

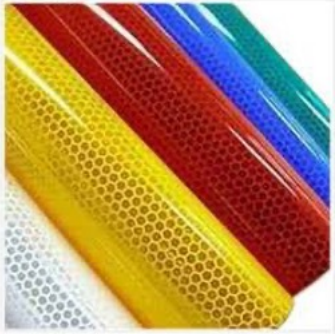
| | |
|---|--|
|  | <p>Contemporary Micro prismatic sheeting</p> <p>Reflectivity: Meets specification ASTM D 4956-04 Type 8</p> <p>Best for: These are used for visibility in any lights or weather conditions. Super Prismatic Grade gives good performance at short sight distance</p> |
|---|--|

E. Premium Prismatic Grade Reflective Sheeting

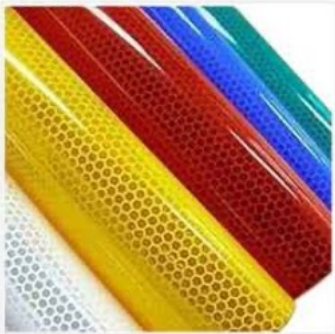
| | |
|--|---|
|  | <p>Contemporary Micro prismatic sheeting</p> <p>Reflectivity: Meets specification ASTM D 4956-04 Type 9 and 11</p> <p>Best for: These are used for visibility in any lights or weather conditions. Super Prismatic Grade gives good performance at short sight distance</p> |
|--|---|

F. Retro Grade Aluminum Composite Panel Sheet: Aluminum Composite Panel Sheet is mainly used for external and internal architectural cladding or partitions, false ceilings, road signages etc. These are also used as an alternative to expensive and heavier substrates. The products flexibility, low weight, easy forming and processing allow for innovative design with increased rigidity and durability.

| | |
|---|---|
|  | <p>Coil Thickness Available: 0.20, 0.25, 0.40 and 0.50 mm</p> |
|---|---|

PREFABRICATED SHELTER

Prefab shelters are mobile construction shelters, usually needed in high altitude regions or sites where constructed shelters cannot be made. It is a practice of assembling a variety of components of a structure at a manufacturing site and transporting those sub-assemblies to the location of the construction job site. These shelters have been high in demand due to their eco-friendliness and lower economic cost.

With the growing development needs and infrastructure in high terrains, the shelters supplied have not been at par with the newer requirements. Our company has constructed and supplied such shelters in order to fulfil these newer needs and keep pace with the changes introduced.

Designed with supreme quality materials for structural elements and insulated panels, every prefabricated shelter manufactured can be modified to comply with any specifications by the customer.



FEATURES OF THE PREFAB SHELTERS ARE AS FOLLOWS:

- ⇒ High Thermal Resistance
- ⇒ Air and Water tight to achieve IP54 level protection
- ⇒ Reinforced ceiling panels / floor panels
- ⇒ Long life with zero maintenance
- ⇒ 3 Way lock and stainless-steel hinges
- ⇒ Complete security
- ⇒ Torque groove configuration with in-built cam locks for more strength

BUILDING AND INFRASTRUCTURE WORKS

With decades of experience in construction works, our company has been executing various civil engineering works which transcends from construction of roads, bridges, building to irrigation and railway systems, adding to the development goal of our nation.

Our company has formed various public-private partnerships for bringing together the best of resources of both sectors to undertake projects with varied demands. In doing so, it has enhanced our experience in undertaking complex projects to create sustainable infrastructure.

Our core competences include:

- **Roads and Highways:**

Across the North Bengal Region, our company has undertaken many turnkey rail and highways infrastructure works which includes national and state highways. Whilst adhering to the international ASTM standards and national MORTH specifications, our company has delivered the projects in a timely manner.

- **Building and Housing:**

With expertise in building and housing infrastructure for over 30 years, our company has been equipped with adequate expertise and manpower to undertake infrastructural projects. Our company has constructed variety of landmark structure for institutional, central and state government buildings.

- **Other Projects:**

Projects on construction of Transmission and Distribution lines or creating a structure of cable system have been undertaken by our company in association with BSNL and MTNL.

Contact us

For any technical queries about our products, you can write to us or call us:

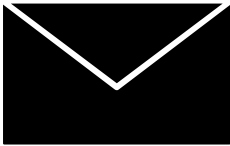

INFO@MKINFRASTRUCTURE.IN

USHANK@MKINFRASTRUCTURE.IN

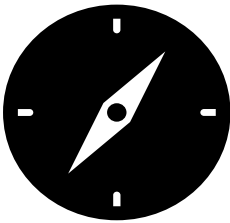

4, AGRASEN ROAD,
SILIGURI - 734005,
WEST BENGAL



+ 91 - 9810166219

+ 91 - 9641330069

0353 - 2502153

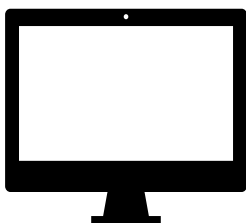

www.mkinfrastructure.in